

Model PTU-D300

Precision Pan/Tilt Unit

High-Speed Positioning of Heavy Payloads

Rugged, Compact, Accurate

The PTU-D300 Standard Model is a computer-controlled pan-tilt unit designed for fast, accurate positioning of heavy payloads. It provides high torque for payloads up to 70 pounds while maintaining speed, precision, and a small form-factor. Its rigid design is ideal for demanding applications that require up to 100% duty-cycles and long life in harsh, all-weather environments.

Key features include:

- Rigid worm gear design (no belts/pulleys) provides steady images in windy environments
- Solid and vibration-tolerant for vehicle-mounted applications
- High holding torque (no sag when powered off)
- Large payload capacity (35 lb top-mount; 70 lb side-mount)
- Wide-range of pan speeds ($<0.0064^\circ/\text{sec}$ to $100^\circ/\text{sec}$)
- Extremely precise positioning (0.0064° with microstep) allows translating object positions to global coordinates accurately
- 360° continuous-pan including pass-through for many payload types (Video, IR, Laser)
- Single connector for all video, control, power interfaces
- Flexible payload mounting (top, side, dual top-side)
- Precise control of position, speed, and acceleration
- Simple control from host computer via RS-232/-485
- Fully sealed for outdoor/marine applications (IP67)
- CE Mark, FCC, RoHS certification

Options:

- Alternate ranges of motion
- Heavy-duty side mount brackets
- Inertial Stabilization Module (ISM)



Applications

- Long-range surveillance
- Airborne sensors and communications
- Antenna positioning systems
- Satellite communications systems
- Laser ranging systems
- Automated video detection and tracking systems
- Industrial automation
- Port security
- Vehicle and shipboard surveillance systems



Surveillance



Military



Remote Sensing



Robotics



Maritime



Antennas



Motion Control Systems

Model PTU-D300

Technical Specifications

Pan/Tilt Performance (Standard)

	Side Mount	Top Mount
Max Payload ¹	70 lb (31.8 kg.)	35 lb (15.9 kg.)
Max Speed ²	50°/second	50°/second

¹ Over-the-top payload assumes COG 6" from tilt axis; over the side payload assumes balanced COG.

² Maximum speed may depend on exact payload configuration and dynamics.

Pan/Tilt Performance (High-Speed Pan)

	Side Mount	Top Mount
Max. Payload	35 lb (15.8 kg)	17.5 lb (17.9 kg)
Max. Pan Speed	100°/second	100°/second
Max. Tilt Speed	50°/second	50°/second

Pan/Tilt Features

Approx. Tilt Range	+30° to -90° from upright (120° range) (up to +/-90° with single side mount)
Approx. Pan Range	360° continuous
Min. Pan Speed	.0064°/second
Min. Tilt Speed	.0064°/second
Pan Position Resolution	.0064° (with microstepping)
Tilt Position Resolution	.0064° (with microstepping)
Duty Cycle	Up to 100% duty cycle, or 3-5 million cycles
Acceleration/Deceleration	On-the-fly speed and position changes

Power Requirements

Input Voltage	Unregulated 12-30 VDC (fastest performance & torque @ 30 VDC)
Power Consumption (Measured at 30 VDC)	49.2 W avg., peak 2.25 A (high power mode) 34.2 W avg., peak 1.60 A (regular power mode) 18.2 W avg., peak 0.78 A (default low power mode) 1.6W (holding power off mode)

Connections & Communications

Base Connectors	PRIMARY: AMP (MIL-C-26482). Includes: PTU-Power (3c) - 9-30 VDC + shield PTU-Control (7c) - RS-232/RS-485 Payload Signals (9-15c) SECONDARY - Reserved
Payload Signal Pass-Through	Power (2c): 30 VDC max. @ 3 A max. Video (4c) Other (3-9c): 30 VDC max. @ 1 A max. Microwave: (DC-18 GHz) (Optional) Custom: Various (Optional)
Computer Controls	RS-232 standard (not on all wiring options); Built-in multidrop RS-485 networking
Control Protocols	DP (ASCII, Binary)

Mechanical

Weight	26 lb (11.8 kg) (Standard bracket: 1.25 lb)
Dimensions	Pan/Tilt Only: 11.61"(h) × 5.53"(w) × 8.53"(d) W/top mount bracket: 13.12"(h) W/side mount bracket: 13.16"(w)
Payload Mounting	Side, top, dual-side+top
PTU Mounting	Pedestal
Material	Machined aluminum

Packaging & Environmental

Standards	Designed to IP67
Operating Temperature	-30°C to +70°C
Humidity	100% relative humidity, non-condensing
Ice (Operating)	Sustained operation with 0.25" ice buildup
Dust/Sand (Operating)	Sustained exposure to blowing dust/sand
Wind/Rain/Fog	IP67
Salt Spray	Sustained operation in salt spray environments
Color/Finish	Black anodized
EMI	CE Mark and FCC Part 15, Subpart B, Class A
Certifications	RoHS Compliant

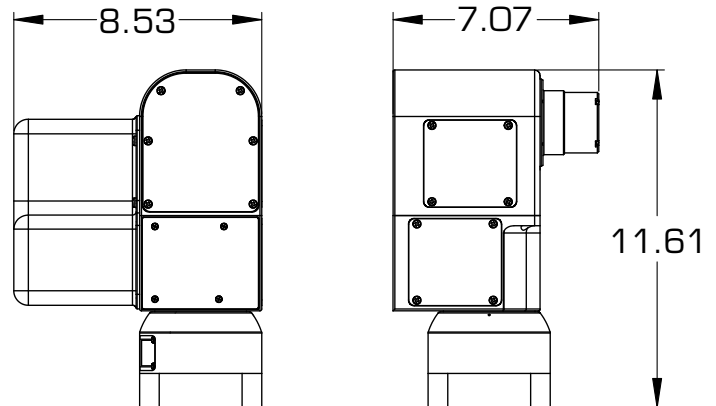

SAN FRANCISCO

FLIR Systems, Inc.
890C Cowan Rd.
Burlingame, CA 94010
USA
PH: + 1 650.692.3900 (Sales)
FX: + 1 650.692.3930
www.FLIR.com/MCS
mcs@flir.com

PORTLAND

CORPORATE HEADQUARTERS
FLIR Systems, Inc.
27700 SW Parkway Ave.
Wilsonville, OR 97070
USA
PH: + 1 650.692.3900 (Sales)

SANTA BARBARA

FLIR Systems, Inc.
70 Castilian Dr.
Goleta, CA 93117
USA
PH: + 1 650.692.3900 (Sales)

THE NETHERLANDS

FLIR Systems BV
Charles Petitweg 21
4847 NW Teteringen - Breda
The Netherlands
PH: +31 (0) 765.794194